Subject: Box with strap holders

Posted by [Jenneke](#) on Tue, 11 Feb 2020 23:06:28 GMT

[View Forum Message](#) <> [Reply to Message](#)

Description

A case wherein the various wrist bands used with wrist watches can be retained. Watch holder notches lined with velvet with a pair of hooks for an extra strap/belt. Under this, place for 6 bands of various materials and colours Recessed with ribs/ridges. A part of these bands can be seen through a window in the velvet upper.

Period : 1922 - 1923?

Watch type : ladies wristwatch

Size : unknown

Inventor : Harold R. Haerr (assignor to the Gruen watch company)

Patents : US1477481A (filed june 15 1922, patented dec 11 1923)

Box maker : unknown

Internet photo user under fair-use for educational and non-commercial purposes

File Attachments

1) [1923 patent.PNG](#), downloaded 644 times

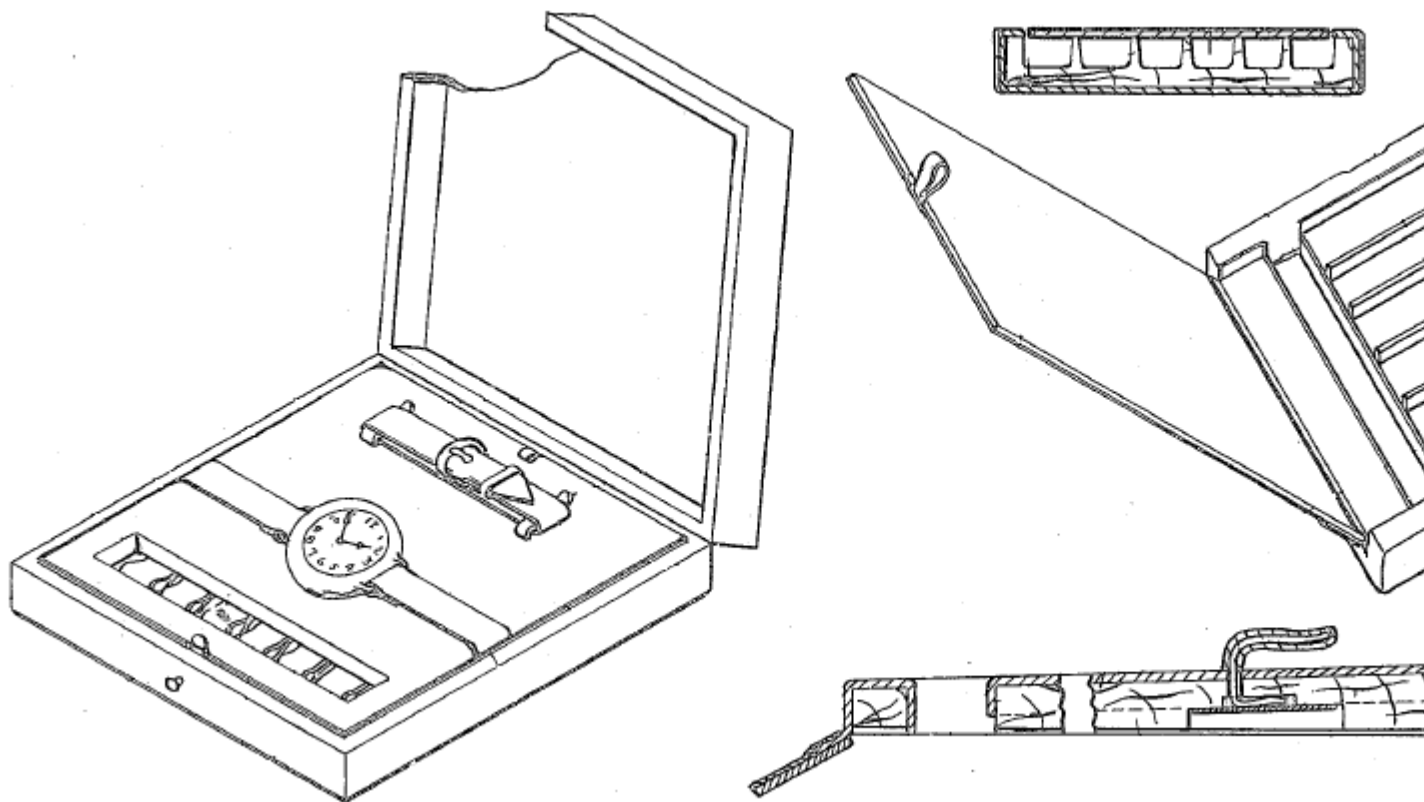

2) [1923 BOX ladies.jpg](#), downloaded 948 times

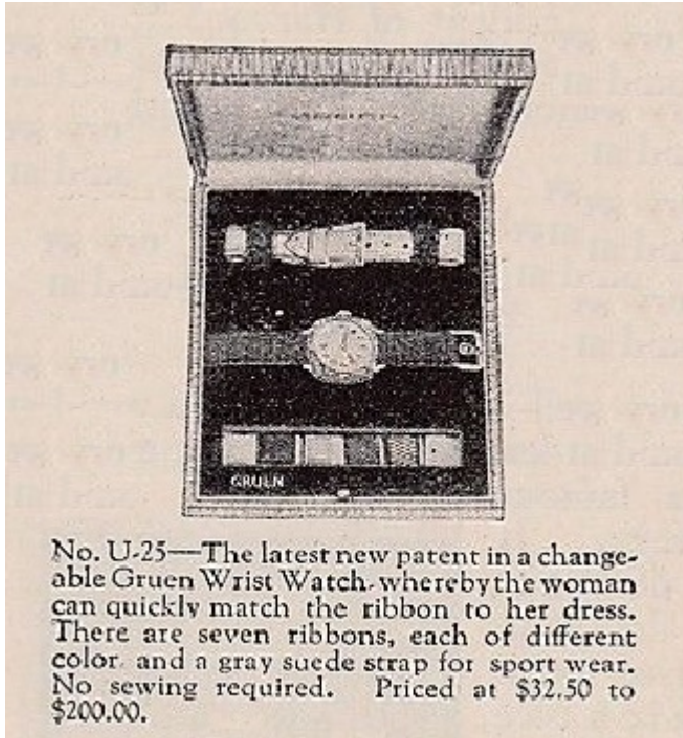

No. U-25—The latest new patent in a changeable Gruen Wrist Watch, whereby the woman can quickly match the ribbon to her dress. There are seven ribbons, each of different color, and a gray suede strap for sport wear. No sewing required. Priced at \$32.50 to \$200.00.

Subject: Re: Box with strap holders
Posted by [Gary](#) on Thu, 13 Feb 2020 01:05:14 GMT
[View Forum Message](#) <> [Reply to Message](#)

Here is another one of Matt's ads that shows this box. Good stuff!